

(NOTE: DESIGNER LOCKER SHOWN WITHOUT SIDE PANEL OR SLOPING HOOD. PLEASE ORDER SEPARATELY.)

NOTES:

MODEL #H31368
12" WIDE DESIGNER WOOD LOCKERS
SINGLE TIER - 3 WIDE

3 LOCKER COMPARTMENTS
EACH COMPARTMENT: 10-3/4"W x 70-1/2"H x 16-3/4"D

SIDE VIEW

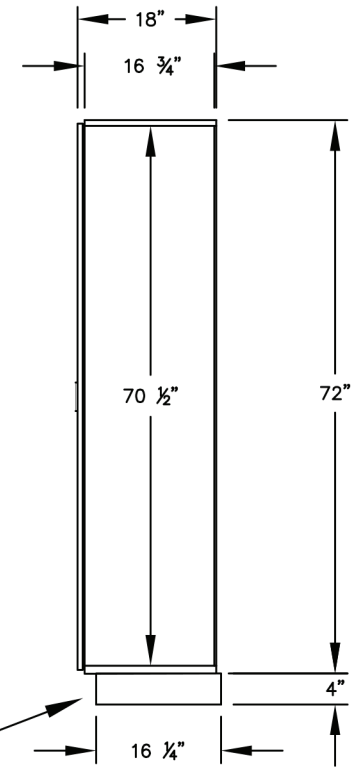

(BASES ARE MADE OF INDUSTRIAL GRADE PARTICLEBOARD AND ARE COVERED IN A DURABLE BLACK LAMINATE. PLEASE SET BASE TO ALLOW 5/8" BETWEEN THE BACK OF THE LOCKER AND THE WALL FOR AIR VENTILATION.)

PRODUCT SERIES:

12" WIDE DESIGNER WOOD LOCKERS



NATIONALMAILBOXES
— A DIVISION OF NMHP INC.

North America's Commercial & Residential Mailbox Leader!

Address: P.O. Box 13144, Wauwatosa, WI 53213
Phone Number: 1-800-676-5161
Website: www.NationalMailboxes.com

MODEL	H31368	REV	
SCALE	NONE	LAST REV DATE	07/2018
DRAWING NUMBER		DRAWN BY	