

(NOTE: DESIGNER LOCKER SHOWN WITHOUT SIDE PANEL OR SLOPING HOOD. PLEASE ORDER SEPARATELY.)

SIDE VIEW

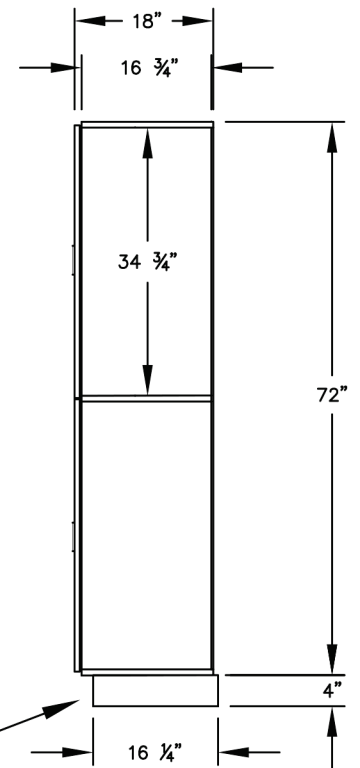

(BASES ARE MADE OF INDUSTRIAL GRADE PARTICLEBOARD AND ARE COVERED IN A DURABLE BLACK LAMINATE. PLEASE SET BASE TO ALLOW 5/8" BETWEEN THE BACK OF THE LOCKER AND THE WALL FOR AIR VENTILATION.)

NOTES:

MODEL #H32368
 12" WIDE DESIGNER WOOD LOCKERS
 DOUBLE TIER - 3 WIDE

6 LOCKER COMPARTMENTS
 EACH COMPARTMENT: 10-3/4"W x 34-3/4"H x 16-3/4"D

PRODUCT SERIES:			
12" WIDE DESIGNER WOOD LOCKERS			
 NATIONALMAILBOXES <small>A DIVISION OF NMHP INC.</small> <small>North America's Commercial & Residential Mailbox Leader!</small> <small>Address: P.O. Box 13144, Wauwatosa, WI 53213</small> <small>Phone Number: 1-800-676-5161</small> <small>Website: www.NationalMailboxes.com</small>	MODEL	H32368	REV
	SCALE	NONE	LAST REV DATE
	DRAWING NUMBER		DRAWN BY
		07/2018	