

(NOTE: DESIGNER LOCKER SHOWN WITHOUT SIDE PANEL OR SLOPING HOOD. PLEASE ORDER SEPARATELY.)

**SIDE VIEW**

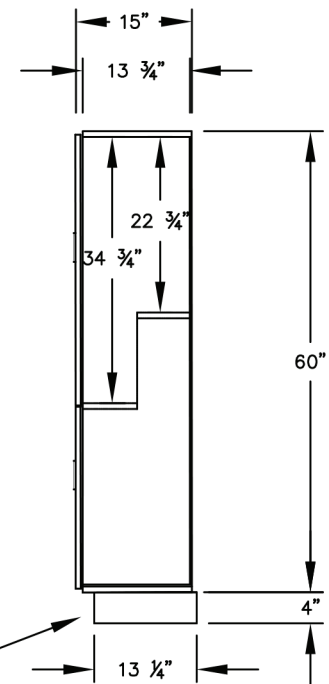

(BASES ARE MADE OF INDUSTRIAL GRADE PARTICLEBOARD AND ARE COVERED IN A DURABLE BLACK LAMINATE. PLEASE SET BASE TO ALLOW 5/8" BETWEEN THE BACK OF THE LOCKER AND THE WALL FOR AIR VENTILATION.)

**NOTES:**

MODEL #H37355

12" WIDE DESIGNER WOOD LOCKERS  
DOUBLE TIER 'S' STYLE - 3 WIDE

6 LOCKER COMPARTMENTS

EACH COMPARTMENT: 10-3/4"W x 34-3/4"H x 13-3/4"D

(THE DOUBLE TIER 'S' STYLE DESIGNER LOCKER INCREASES EACH COMPARTMENT ON ONE SIDE TO ACCOMMODATE GARMENTS.)

PRODUCT SERIES:

**12" WIDE DESIGNER WOOD LOCKERS**



**NATIONALMAILBOXES**  
— A DIVISION OF NMHP INC.

*North America's Commercial & Residential Mailbox Leader!*

Address: P.O. Box 13144, Wauwatosa, WI 53213  
Phone Number: 1-800-676-5161  
Website: [www.NationalMailboxes.com](http://www.NationalMailboxes.com)

MODEL	H37355	REV	
SCALE	NONE	LAST REV DATE	07/2018
DRAWING NUMBER		DRAWN BY	