

(NOTE: DESIGNER LOCKER SHOWN WITHOUT SIDE PANEL OR SLOPING HOOD. PLEASE ORDER SEPARATELY.)

**NOTES:**

MODEL #H23161  
 15" WIDE DESIGNER WOOD LOCKERS  
 TRIPLE TIER - 1 WIDE

3 LOCKER COMPARTMENTS  
 EACH COMPARTMENT: 13-3/4"W x 22-3/4"H x 19-3/4"D

SIDE VIEW

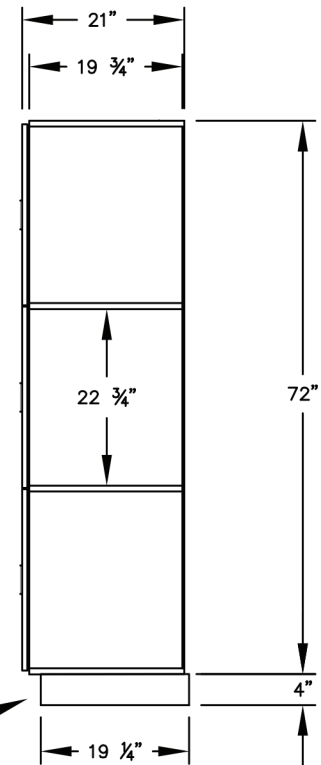

(BASES ARE MADE OF INDUSTRIAL GRADE PARTICLEBOARD AND ARE COVERED IN A DURABLE BLACK LAMINATE. PLEASE SET BASE TO ALLOW 5/8" BETWEEN THE BACK OF THE LOCKER AND THE WALL FOR AIR VENTILATION.)

PRODUCT SERIES:			
<b>15" WIDE DESIGNER WOOD LOCKERS</b>			
 <b>NATIONALMAILBOXES</b> <small>A DIVISION OF NMHP INC.</small> <small>North America's Commercial &amp; Residential Mailbox Leader!</small> <small>Address: P.O. Box 13144, Wauwatosa, WI 53213</small> <small>Phone Number: 1-800-676-5161</small> <small>Website: www.NationalMailboxes.com</small>	MODEL	H23161	REV
	SCALE	NONE	LAST REV DATE
DRAWING NUMBER		DRAWN BY	
		07/2018	