

BASE BOLT PATTERN

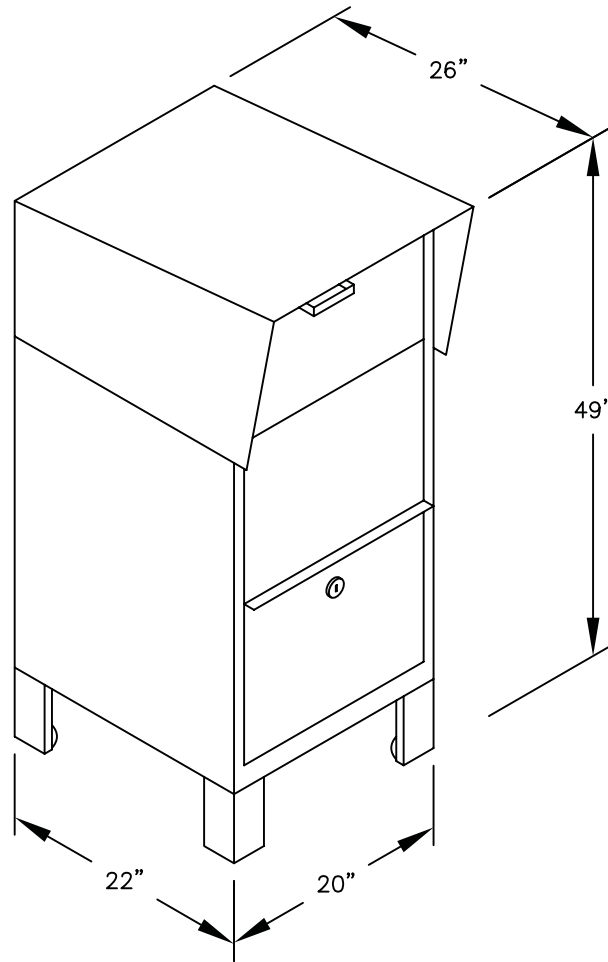

SIDE VIEW

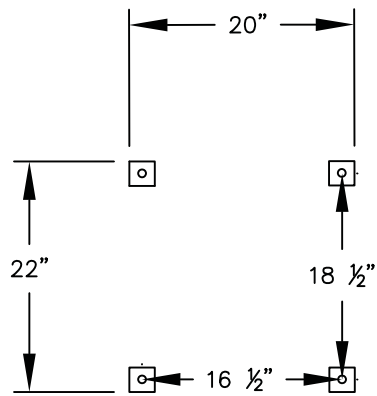
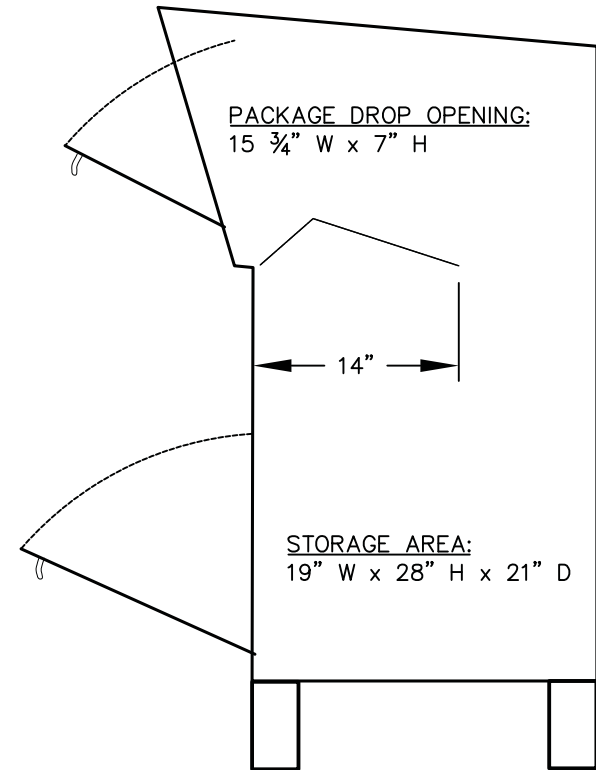

MODEL #H4975
COURIER BOX



NATIONALMAILBOXES
A DIVISION OF NMHP INC.

North America's Commercial & Residential Mailbox Leader!

Contact Info:

Phone: 1-800-676-5161

Address: P.O. Box 13144

Wauwatosa, WI 53213

Email: Info@NationalMailboxes.com

Web: www.NationalMailboxes.com